



AKKO®

*konusulan
the spoken kalite...
quality...*



T-SİSTEM

T-SİSTEM İÇTEN SOĞUTMA KANALLI DIŞ TORNA KATERLERİ
T-SYSTEM EXTERNAL TURNING TOOLHOLDERS WITH COOLANT TOOLS
T-SYSTEM AUSSEN - DREHHALTER MIT INNENKÜHLUNG



DETAYLI BİLGİ İÇİN BARKODU OKUTUNUZ

SCAN ME FOR MORE DETAILS

SCANNEN SIE MICH NACH WEITEREN DETAILS

PRODUŽITE ŽIVOTNI VIJEK REZNE PLOČICE

Cijenjeni Poslovni Partneri

Svi smo sudionici težine trenutne ekonomske situacije koju nam donosi današnjica , a svakako i mogućih posljedica koje bi se mogle odraziti na poslovanje u narednoj poslovnoj godini.

Svaki proizvođač MAŠINSKI OBRAĐENIH DIJELOVA u ovom trenutku ima namjeru da reducira troškove proizvodnog procesa , a kao jedna od mogućnosti jeste SMANJENJE TROŠKOVA REZNIH ALATA PO OBRAĐENOM PROIZVODU.

Zbog toga vlada sveošta težnja da se pronađu novi jeftiniji dobavljači koji bi mogli da ponude niže dobavne cijene uz istovremeno osiguranje najmanje istog kvaliteta reznog alata.

Firma Project Solutions kao provider reznih alata isto tako KONSTANTNO teži da obezbijedi i ponudi ALTERNATIVNE REZNE ALATE koji bi mogli da utiču na smanjenje troškova proizvodnog procesa kod naših kupaca.

Zbog toga vam se ovaj put obraćamo s namjerom prezentacije "AKKO" DRŽAČA ALATA ZA VANJSKO STRUGANJE KOJI POSJEDUJU DVOZONSKO UNUTRAŠNJE HLAĐENJE :

- Zona 1 : Usmjereno Hlađenje preko stezne šape na GRUDNU POVRŠINU REZNE OŠTRICE.
- Zona 2 : Usmjereno Hlađenje na LEĐNU POVRŠINU REZNE OŠTRICE

Ovi nosači svojim usmjerenim hlađenjem sa kratkog rastojanja utiču na POVEĆANJE ŽIVOTNOG VIJEKA REZNE OŠTRICE OD 30% - 100%

Klikom na link ispod , možete na našoj Facebook stranici pogledati video prezentaciju navedenih prihvata i njihovo konstrukciono rješenje :

<https://www.facebook.com/100516738536814/videos/1760700104083199>

Ulaganje u ovakve prihvate je za vrlo mali iznos skuplje od običnih držača reznih alata , a kao BENEFIT KUPCIMA može donijeti VELIKE UŠTEDE na postojećim reznim pločicama bez bilo kakvih drugih izmjena.

U nastavku vam prezentiramo trenutnu specifikaciju držača reznih alata (Proizvodni Program) , od kojih se neki upravo nalaze u AKCIJSKOJ PONUDI , što ih čini vrlo pristupačni za testiranje :

AKKO : PATENTIRANO HLADJENJE



KAPR=95°

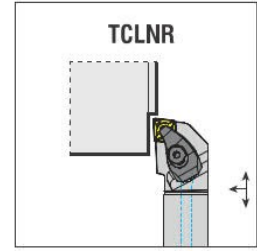
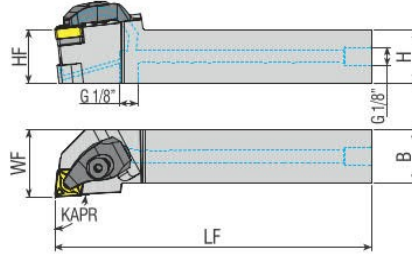

Takım Kodu Ordering Code Bestell-Bezeichnung	Stok Stock Lager		Takım Ölçüleri (mm) Dimension (mm) Abmessung (mm)				Kesici Uç Insert Wendeschneidplatte	Yedek Parçaları / Spare Parts / Ersatzteile								
	R	L	HF=H	B	LF	WF		Baskı Pabucu Wedge Clamp Spannpratze	Pabuç Vidası Clamp Screw Klemmschraube	Altlık Shim Unterlage	Altlık Vidası Shim Screw Schraube für Unterlage	Yay Spring Feder	Oring Ring Feder	Sızdırmaz Vidası Threaded Pin Gewindestift	Anahtar Allen Key Innensechskantschlüssel	
TCLNR/L 2020 K12-H	●	●	20	20	125	25	CNM. 1204..									
2525 M12-H	●	●	25	25	150	32										
3232 P12-H	●	●	32	32	170	40										



KAPR=93°

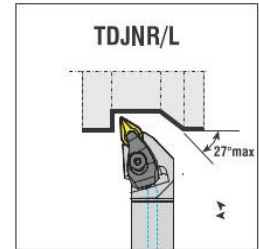
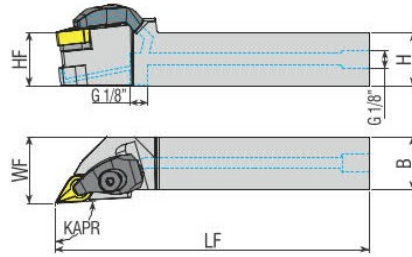

Takım Kodu Ordering Code Bestell-Bezeichnung	Stok Stock Lager		Takım Ölçüleri (mm) Dimension (mm) Abmessung (mm)				Kesici Uç Insert Wendeschneidplatte	Yedek Parçaları / Spare Parts / Ersatzteile									
	R	L	HF=H	B	LF	WF		Baskı Pabucu Wedge Clamp Spannpratze	Pabuç Vidası Clamp Screw Klemmschraube	Altlık Shim Unterlage	Altlık Vidası Shim Screw Schraube für Unterlage	Yay Spring Feder	Oring Ring Feder	Sızdırmaz Vidası Threaded Pin Gewindestift	Anahtar Allen Key Innensechskantschlüssel		
TDJNR/L 2020 K15-H	●	●	20	20	125	25	DNM. 1506..									Cijena (KM)	Stanje (kom)
2525 M15-H	●	●	25	25	150	32										79,40	28
3232 P15-H	●	●	32	32	170	40										82,20	43
																92,20	30

R: Sağ / Right / Rechts L: Sol/Left/Links

● Stokta / In Stock / Auf Lager ○ Stokta Yok / Non Stock Item / Kein Lagerartikel, Lieferzeit auf Anfrage

Sipariş Örneği/Ordering Example/Bestellbeispiel

1 ad./pcs./stück TCLNR 2020 K12-H



SİSTEM İÇTEN SOĞUTMA KANALLI DIŞ TORNA KATERLERİ
SYSTEM EXTERNAL TURNING TOOLHOLDERS WITH COOLANT TOOLS
SYSTEM AUSSEN - DREHHALTER MIT INNENKÜHLUNG



AKKO : PATENTIRANO HLADJENJE



KAPR=62.5°

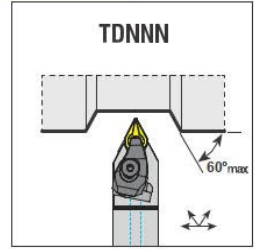
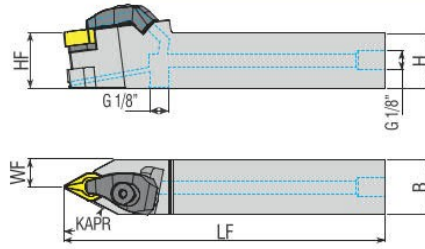

Takım Kodu Ordering Code Bestell-Bezeichnung	Stok Stock Lager		Takım Ölçüleri (mm) Dimension (mm) Abmessung (mm)				Kesici Uç Insert Wendeschneidplatte	Yedek Parçaları / Spare Parts / Ersatzteile									
	R	L	HF=H	B	LF	WF		Baskı Pabucu Wedge Clamp Spannpratze	Pabuç Vidası Clamp Screw Klemmschraube	Altlık Shim Unterlage	Altlık Vidası Shim Screw Schraube für Unterlage	Yay Spring Feder	Oring Ring Feder	Sızdırmaz Vida Threaded Pin Gewindestift	Anahtar Allen Key Innensechskantschlüssel		
TDNNN 2525 M15-H	●		25	25	150	32	DNM. 1506..	ATKH-01-R	AKV-33-M6x22	AAVN-3-0001	AAV-02-M5x12	AKY-01	AXR-01	2705-G1/8x5.5	AAL-03-3		



KAPR=95°

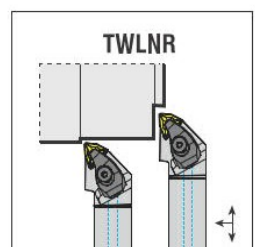
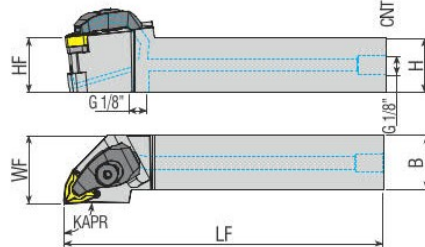

Takım Kodu Ordering Code Bestell-Bezeichnung	Stok Stock Lager		Takım Ölçüleri (mm) Dimension (mm) Abmessung (mm)				Kesici Uç Insert Wendeschneidplatte	Yedek Parçaları / Spare Parts / Ersatzteile											
	R	L	HF=H	B	LF	WF		Baskı Pabucu Wedge Clamp Spannpratze	Pabuç Vidası Clamp Screw Klemmschraube	Altlık Shim Unterlage	Altlık Vidası Shim Screw Schraube für Unterlage	Yay Spring Feder	Oring Ring Feder	Sızdırmaz Vida Threaded Pin Gewindestift	Anahtar Allen Key Innensechskantschlüssel				
TWLNR/L 2020 K08-H	●	●	20	20	125	25	WNM. 0804..	ATKH-01-R ATKH-02-L	AKV-33-M6x22	AAVN-3-0001	AAV-02-M5x12	AKY-01	AXR-01	2705-G1/8x5.5	AAL-03-3	Cijena (KM)	Stanje (kom)		
2525 M08-H	●	●	25	25	150	32												79,40	27
3232 P08-H	●	●	32	32	170	40												82,20	44

R: Sağ / Right / Rechts L: Sol/Left/Links

● Stokta / In Stock / Auf Lager ○ Stokta Yok / Non Stock Item / Kein Lagerartikel, Lieferzeit auf Anfrage

Sipariş Örneği/Ordering Example/Bestellbeispiel

1 ad./pcs./stück TDNNN 2525 M15-H

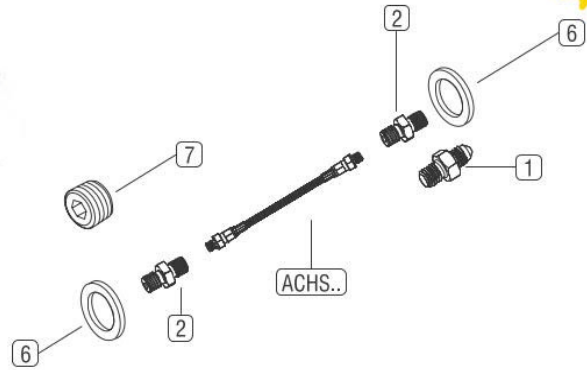
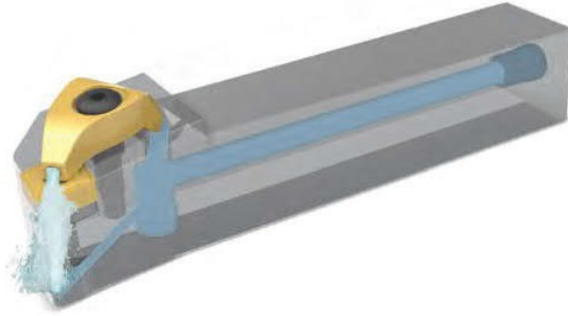

Not: İçten soğutmalı tüm torna katerlerinde kullanılabilecek 3 tip soğutma hortum setleri tasarlanmıştır. Takımların kullanılmasından önce, kullanılmayan bağlantıların set içindeki vida ile kapatılarak sızdırmazlığın sağlanmasına dikkat edilmelidir. Torna katerlerine yönelik soğutma hortum setleri, ACHS... 10 bar ile maksimum 275 bar basınç aralığında kullanılabilir.

Note: 3 types of cooling hose sets are designed that can be used in all internally cooled lathes. Before using the tools, care should be taken to ensure that the unused connections are closed with the screw in the set and that sealing is ensured. Cooling hose sets for lathe tools can be used in the pressure range of ACHS ... 10 bar to max 275 bar.

Notiz: Es wurden 3 Arten von Kühlschlauch-Sets entwickelt, die in allen intern gekühlten Drehmaschinen verwendet werden können. Vor der Verwendung der Werkzeuge sollte darauf geachtet werden, dass die nicht verwendeten Verbindungen mit der Schraube im Satz geschlossen werden und die Abdichtung gewährleistet ist. Kühlschlauchsätze für Drehmaschinen können im Druckbereich von ACHS ... 10 bar bis max. 275 bar eingesetzt werden.

Set içindeki Parçalar Parts In The Set Teile im Set				Uzunluk / Length Code / Länge		
Resim Picture Bild	Takım Kodu Set Code Code Einstellen	Ürün Açıklaması Product Description Artikelbeschreibung	Set Kodu: Set Code: Code Einstellen: ACHS-1-250	Set Kodu: Set Code: Code Einstellen: ACHS-2-250	Set Kodu: Set Code: Code Einstellen: ACHS-3-250	
1	AMP-01	M10 Bağlantı Elemanı M10 Fastener M10 Verschluss	1x	-	-	
2	AMP-02	G 1/8" Çift Bağlantı Elemanı G 1/8" Double Fastener G 1/8" Doppelverschluss	2x	1x	-	
3	AMP-03	G 1/8" Açılı Bağlantısı G 1/8" Angle Connection G 1/8" Winkelverbindung	-	1x	2x	
4	AMP-04	M10" Açılı Bağlantısı M10" Angle Connection M10" Winkelverbindung	-	1x	1x	
5	AMP-05	G1/4"-G1/8" Kısılma Parçası G1 / 4"-G1/8" Capillary Piece G1 / 4"-G1/8" Kapillarstück	-	1x	1x	
6	AG-01	Bakır Conta Copper Gasket Kupferdichtung	2x	3x	4x	
7	2705-G1/8-5.5	G1/8" Sızdırmaz Civata G1/8" Sealing Bolt G1/8" Dichtungsschraube	1x	1x	1x	
8	AH-1-250	Hortum Hose Schlauch	1x	-	-	
9	AH-2-250	Hortum Hose Schlauch	-	1x	-	
10	AH-3-250	Hortum Hose Schlauch	-	-	1x	



P-SİSTEM

P-SİSTEM İÇTEN SOĞUTMA KANALLI DIŞ TORNA KATERLERİ
P-SYSTEM EXTERNAL TURNING TOOLHOLDERS WITH COOLANT TOOLS
P-SYSTEM AUSSEN - DREHHALTER MIT INNENKÜHLUNG

konusulan
the spoken kalite...
quality...



DETAYLI BİLGİ İÇİN BARKODU OKUTUNUZ
SCAN ME FOR MORE DETAILS
SCANNEN SIE MICH NACH WEITEREN DETAILS



SİSTEM İÇTEN SOĞUTMA KANALLI DIŞ TORNA KATERLERİ
SYSTEM EXTERNAL TURNING TOOLHOLDERS WITH COOLANT TOOLS
SYSTEM AUSSEN - DREHHALTER MIT INNENKÜHLUNG



ORIGINAL : AKKO PATENTIRANO HLADJENJE

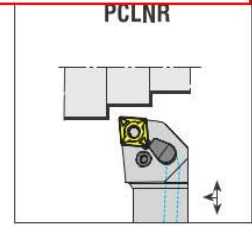
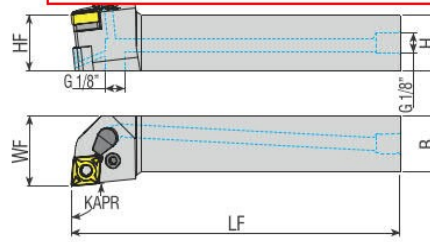

Takım Kodu Ordering Code Bestell-Bezeichnung	Stok Stock Lager		Takım Ölçüleri (mm) Dimension (mm) Abmessung (mm)				Kesici Uç Insert Wendeschneidplatte	Levyeye Lever Kniehebel	Levyeye Vidası Lever Screw Kniehebelschraube	Altılık Shim Unterlage	Altılık Yayı Shim Spring Feder für Unterlage	Oring Ring Feder	Sızdırmaz Vida Threaded Pin Gewindestift	Nozzle Nozzle	Anahtar Allen Key Innensechskantschlüssel
	R	L	HF=H	B	LF	WF									
PCLNR/L 2020 K12-H	●	●	20	20	125	25	CNM. 1204..	APL-02	ALV-03-M8x19	AACN-3-0001	AAY-02	AXR-01 AOR-01	2705-G1/8x5.5	AN-01	AAL-03-3
2525 M12-H	●	●	25	25	150	32									
3232 P12-H	●	○	32	32	170	40									

AKKO : PATENTIRANO HLADJENJE

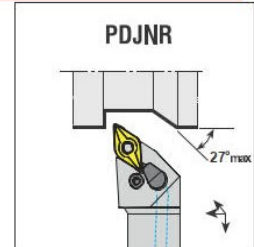
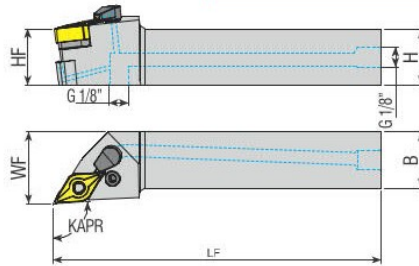

Takım Kodu Ordering Code Bestell-Bezeichnung	Stok Stock Lager		Takım Ölçüleri (mm) Dimension (mm) Abmessung (mm)				Kesici Uç Insert Wendeschneidplatte	Levyeye Lever Kniehebel	Levyeye Vidası Lever Screw Kniehebelschraube	Altılık Shim Unterlage	Altılık Yayı Shim Spring Feder für Unterlage	Oring Ring Feder	Sızdırmaz Vida Threaded Pin Gewindestift	Nozzle Nozzle	Anahtar Allen Key Innensechskantschlüssel			
	R	L	HF=H	B	LF	WF												
PDJNR/L 2020 K15-H	●	●	20	20	125	25	DNM. 1506..	APL-03	ALV-03-M8x19	AADN-3-0001	AAY-02	A	A	Cijena (KM)	Stanje (kom)			
2525 M15-H	●	●	25	25	150	32										64,00	42	
3232 P15-H	●	○	32	32	170	40										66,60	51	
																	74,30	36

R: Sağ / Right / Rechts L: Sol/Left/Links

● Stokta / In Stock / Auf Lager ○ Stokta Yok / Non Stock Item / Kein Lagerartikel, Lieferzeit auf Anfrage

Sipariş Örneği/Ordering Example/Bestellbeispiel

1 ad./pcs./stück PCLNR 2020 K12-H



www.akk.com.tr



KAPR=62.5°

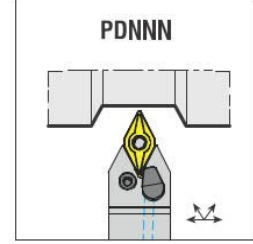
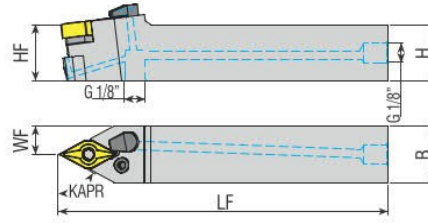

Takım Kodu Ordering Code Bestell-Bezeichnung	Stok Stock Lager	Takım Ölçüleri (mm) Dimension (mm) Abmessung (mm)				Kesici Uç Insert Wendeschneidplatte	Yedek Parçaları / Spare Parts / Ersatzteile									
		HF=H	B	LF	WF		Levyeye Lever Kniehebel	Levyeye Vidası Lever Screw Kniehebelschraube	Altlık Shim Unterlage	Altlık Yay Shim Spring Feder für Unterlage	Oring Ring Feder	Sızdırmaz Vida Threaded Pin Gewindestift	Nozzle Nozzle Nozzle	Anahtar Allen Key Innerschraubenschlüssel		
PDNNN 2525 M15-H	●	25	25	150	32	DNM. 1506..	APL-03	ALV-03-M8x19	AADN-3-0001	AAAY-02	AXR-01 AOR-01	2705-G1/8x5.5	AN-01	AAL-03-3		



KAPR=95°

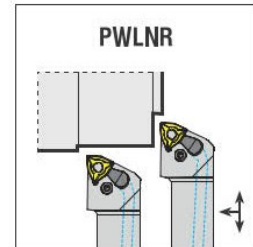
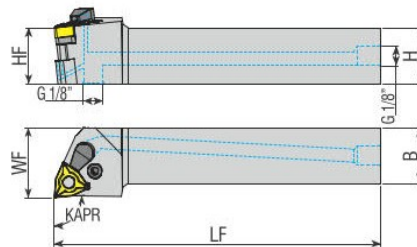

Takım Kodu Ordering Code Bestell-Bezeichnung	Stok Stock Lager	Takım Ölçüleri (mm) Dimension (mm) Abmessung (mm)				Kesici Uç Insert Wendeschneidplatte	Yedek Parçaları / Spare Parts / Ersatzteile									
		R	L	HF=H	B		LF	WF	Levyeye Lever Kniehebel	Levyeye Vidası Lever Screw Kniehebelschraube	Altlık Shim Unterlage	Altlık Yay Shim Spring Feder für Unterlage	Oring Ring Feder	Sızdırmaz Vida Threaded Pin Gewindestift	Nozzle Nozzle Nozzle	Anahtar Allen Key Innerschraubenschlüssel
PWLNR/L 2020 K08-H	●	●	20	20	125	25	WNM. 0804..	APL-02	ALV-03-M8x19	AAWN-3-0001	AAAY-02	AXR-01 AOR-01	2705-G1/8x5.5	AN-01	AAL-03-3	
2525 M08-H	●	●	25	25	150	32										

R: Sağ / Right / Rechts L: Sol/Left/Links

● Stokta / In Stock / Auf Lager ○ Stokta Yok / Non Stock Item / Kein Lagerartikel, Lieferzeit auf Anfrage

Sipariş Örneği/Ordering Example/Bestellbeispiel

1 ad./pcs./stück PDNNN 2525 M15-H



İÇTEN SOĞUTUCU HORTUM SETLERİ INTERNAL COOLING HOSE SETS INLERSCHLAUCHSÄTZE

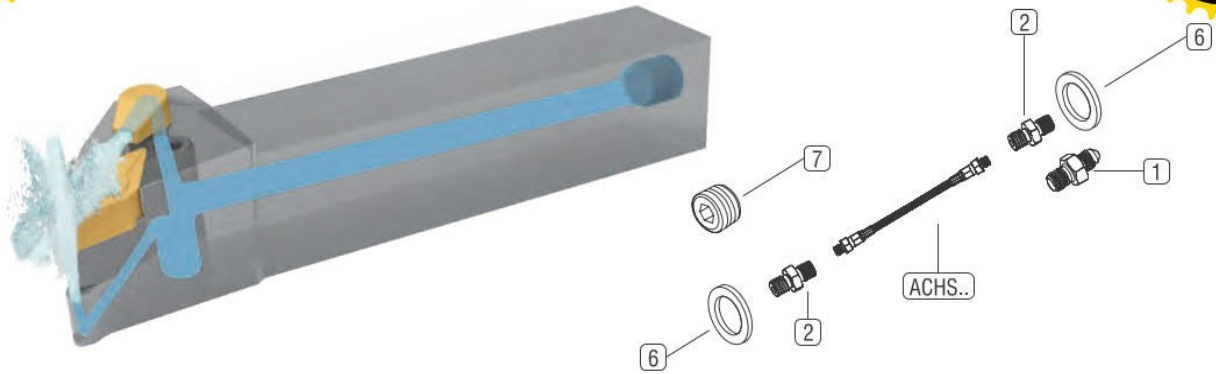

Not: İçten soğutmalı tüm torna katerlerinde kullanılabilen 3 tip soğutma hortum setleri tasarlanmıştır. Takımların kullanılmasından önce, kullanılmayan bağlantıların set içindeki vida ile kapatılarak sızdırmazlığın sağlanmasına dikkat edilmelidir. Torna katerlerine yönelik soğutma hortum setleri, ACHS... 10 bar ile maksimum 275 bar basınç aralığında kullanılabilir.

Note: 3 types of cooling hose sets are designed that can be used in all internally cooled lathes. Before using the tools, care should be taken to ensure that the unused connections are closed with the screw in the set and that sealing is ensured. Cooling hose sets for lathe tools can be used in the pressure range of ACHS ... 10 bar to max 275 bar.

Notiz: Es wurden 3 Arten von Kühlschlauch-Sets entwickelt, die in allen intern gekühlten Drehmaschinen verwendet werden können. Vor der Verwendung der Werkzeuge sollte darauf geachtet werden, dass die nicht verwendeten Verbindungen mit der Schraube im Satz geschlossen werden und die Abdichtung gewährleistet ist. Kühlschlauchsätze für Drehmaschinen können im Druckbereich von ACHS ... 10 bar bis max. 275 bar eingesetzt werden.

Set İçindeki Parçalar Parts In The Set Teile im Set				Uzunluk / Length Code / Länge		
				Set Kodu: Set Code: Code Einstellen:	Set Kodu: Set Code: Code Einstellen:	Set Kodu: Set Code: Code Einstellen:
				ACHS-1-250	ACHS-2-250	ACHS-3-250
	Resim Picture Bild	Takım Kodu Set Code Code Einstellen	Ürün Açıklaması Product Description Artikelbeschreibung			
1		AMP-01	M10 Bağlantı Elemanı M10 Fastener M10 Verschluss	1x	-	-
2		AMP-02	G 1/8" Çift Bağlantı Elemanı G 1/8" Double Fastener G 1/8" Doppelverschluss	2x	1x	-
3		AMP-03	G 1/8" Açılı Bağlantısı G 1/8" Angle Connection G 1/8" Winkelverbindung	-	1x	2x
4		AMP-04	M10" Açılı Bağlantısı M10" Angle Connection M10" Winkelverbindung	-	1x	1x
5		AMP-05	G1/4"-G1/8" Kılcalma Parçası G1/4"-G1/8" Capillary Piece G1/4"-G1/8" Kapillarstück	-	1x	1x
6		AG-01	Bakır Conta Copper Gasket Kupferdichtung	2x	3x	4x
7		2705-G1/8-5.5	G1/8" Sızdırmaz Civata G1/8" Sealing Bolt G1/8" Dichtungsschraube	1x	1x	1x
8		AH-1-250	Hortum Hose Schlauch	1x	-	-
9		AH-2-250	Hortum Hose Schlauch	-	1x	-
10		AH-3-250	Hortum Hose Schlauch	-	-	1x